

AMSTEL ROLLING SHUTTERS

Instructions for installation and maintenance of Amstel Rolling Shutters Models PF100 and CF100 Face of Wall and Models PJ100 and CJ100 Between Jamb Mounted, Manually or Hand Crank operated.

GENERAL TERMS: Right Hand (R.H.) and Left Hand (L.H.) are to be read looking at the shutter from the inside, or hood – or coil side.

IMPORTANT: These instructions are to be read in conjunction with the accompanying drawing(s).

Each shutter consists of:

- (1) One R.H. Guide assembly complete with guide, R.H. bracket with lug and stopper.
- (1) One L.H. Guide assembly complete with guide, L.H. bracket with lug and stopper.
or
- (1) One L.H. Guide assembly complete with guide, L.H. bracket with 3/8" nut, lug and a stopper. Face of Wall Mount ONLY.
- (1) One shutter curtain consisting of slats, endlocks, bottom bar, lift handles and slide bolts, if specified.
- (1) One pipe barrel assembly consisting of a shaft, pipe, barrel rings, the interior mounted castings and a spring.
- (1) One hood, fascia and/or soffit, if applicable.

Before commencing installation, it is a good precaution to cut a wood gauge rod equal in length to the distance between the guides. See also drawing shipped with door.

GENERAL STEPS FOR INSTALLATION:

Step 1: Compare opening size with measurement of drawings. This is very important.

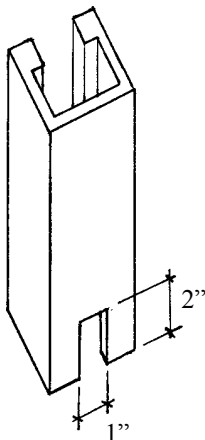

Step 2: Remove stops from guide assemblies and hold guide assemblies against wall to measurements as per drawings. The guide assemblies must be plumb and parallel and the brackets must be level with each other. Mark the location of the mounting holes and drill pilot holes for the fasteners provided.

Additionally For Between Jamb Mounting: Also mark the location of the cutout in the bottom of the guide (see illustration of back of guide at left). Remove the guide from the wall and cut out the material in the area that you have traced. This recess is for the locking bolt.

Cont'd...

Amstel

111 CARLAUREN ROAD
WOODBIDGE, ONTARIO, L4L 8A8
TEL.(905) 850-7122 FAX.(905) 850-7336
1-800-663-6206

- Step 3: Mount guide assemblies to wall with fasteners provided and recheck for square and level.
- Step 4: Take pipe barrel assembly and place the assembly between brackets. (Remove adjusting wheel if F.O.W. mount) The assembly must be level and be able to spin freely.
- Step 5: Take curtain assembly and feed it into the guides from the top. Place it in position so that it is centered between the brackets.
- Step 6: Fasten shutter with supplied 1/4" diam. x 3/8" hex socket round head screws to barrel rings. Recheck clearance on each side.
- Step 7: B/J Mount: Put stops back on to guides. Using two winding bars wind the adjusting wheel in the direction of arrow marked on pipe barrel (downwards) until shutter starts to rise. Put locking bolt back through lug and shaft and tighten with 1/4" hex. nut.
- Step 8: FOW Mount: Put adjusting wheel back on L.H. side of shaft, outside of L.H. bracket and fasten it to the shaft with spring pin.
- Step 9: FOW Mount: Using two winding bars, wind the adjusting wheel in direction of the arrow marked on the pipe barrel (downwards), until shutter starts to rise. Put locking bolt back into bracket.
- Step 10: The shutter should coil easily up and down and stay up once the bottom bar hits the stops. If readjustment is required remove lockbolt from lug and turn adjusting wheel as above to increase spring tension, or opposite direction to decrease tension.
- Step 11: After securing the adjusting wheel with locking bolt move shutter up and down several times to make sure it is working properly. Now take hood, fascia or soffit and fasten them to angles on brackets with 10-32 round head screws provided.

INSTALLATION OF HAND CRANK OPERATED SHUTTERS BETWEEN JAMB MOUNTED (CJ-100)

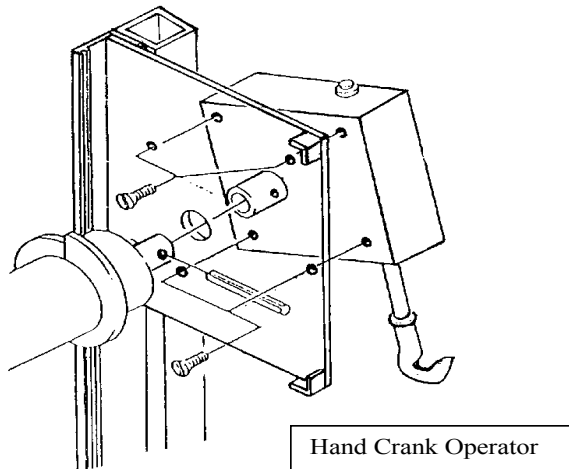

The installation procedure is the same as mentioned before, with only two exceptions. The R.H. bracket will have no lug but a gearbox attached to it, and the shaft of the pipe barrel assembly is in two pieces (internally) and extends further on the right side.

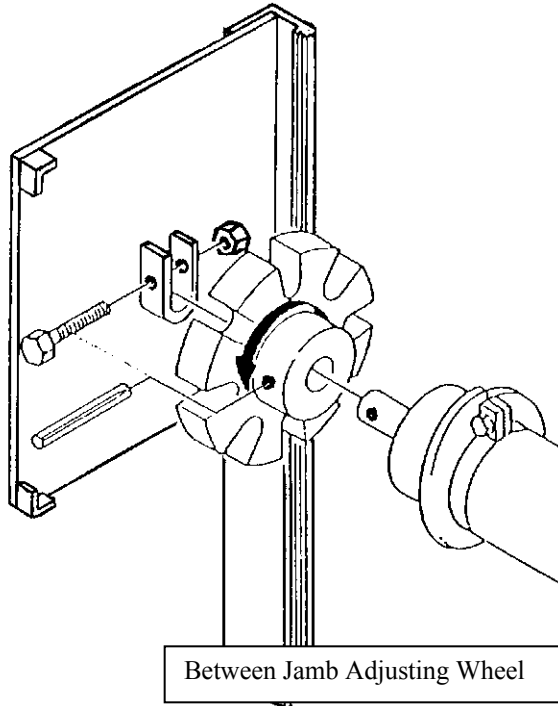

Steps 1 and 2 are the same as before.

Step 3: Mount L.H. guide assembly to wall.

Step 4: Take pipe barrel assembly, insert it into gearbox collar on R.H. bracket and insert left end of pipe barrel into lug of left hand bracket. Now fasten R.H. guide assembly to wall. Check if pipe assembly spins freely.

Steps 5 to 7 same as before.

Step 8: Secure it to gearbox collar with 1/4" bolt and nut.

Step 9: Check spring tension. See step 10 as before.

Step 10: Install hood. See step 11 as before.

INSTALLATION OF HAND CRANK OPERATED SHUTTERS **FACE OF WALL MOUNTED (CF-100)**

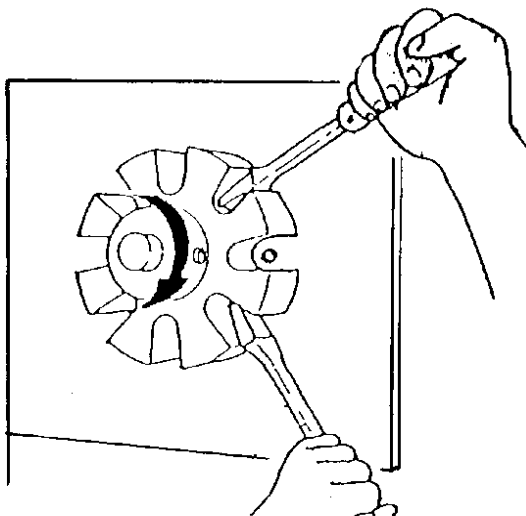

Face of Wall Adjusting Wheel

Note: We recommend that you use 3/8" thick x 3/4" wide steel flat bars as winding tools instead of screwdrivers as shown in the illustration.

The installation procedure is the same as mentioned before with only two exceptions. The R.H.

bracket will have no lug but a gearbox attached to it and the shaft of the pipe barrel assembly is in two pieces (internally) and extends further on the right side.

Steps 1 and 2 are the same as before.

Step 3: Mount L.H. guide assembly to wall.

Step 4: Remove adjusting wheel of pipe barrel assembly and insert the assembly into L.H. guide assembly. Take R.H. guide assembly and insert it into the right end of the pipe barrel assembly and fasten the R.H. guide assembly to wall. Check if the pipe barrel assembly is free spinning.

Steps 5 to 7 same as before.

Cont'd...

Step 8: Put adjusting wheel back on L.H. side of shaft, outside of L.H. bracket and fasten it to shaft with spring pin. Fasten shaft to gearbox with 1/4" bolt and nut.

Steps 9 to 10 same as before.

SPECIAL NOTES: On between jamb installations ensure that cutouts for locking bolts are unobstructed.

MAINTENANCE INSTRUCTIONS:

The guides should be kept clean of dirt, particularly in the area of the bottom of the guide pocket where dust and dirt can accumulate. On both anodized aluminum and stainless steel curtains, the curtains should be cleaned minimum once a year with a damp rag and a non-abrasive cleaner. For crank operated shutters grease the gear box once a year. At least once a year the curtain balance should be checked and the spring tension should be adjusted if necessary.