

# AMSTEL FOLDING GRILLES

## Instructions for installation and maintenance of Amstel Folding Grilles Models: Vista, Air Vista, Solid Vista, Guardian, Sentry and Classic 126

---

### IMPORTANT:

1. These instructions are to be read in conjunction with the accompanying drawing(s) for the specific grille to be installed.
2. Before commencing installation of the grille it is vital to make final site measurements to ensure that the grille can be installed properly. Check the opening height and width and compare them to the drawing supplied with the grille to confirm that they are identical. If they are not, consult Amstel Manufacturing immediately to determine remedies.
3. Inspect the bulkhead carefully to ensure that the wood blocking and structural support, that the track will fasten to, will be sufficient to support the grille weight. Structural support must run the entire length of the track. It is extremely important to verify the structural support in the area(s) where the grille will stack because this is the point where the greatest stresses on the support will be during day to day operation of the grille. Note: The drawing supplied with the grille has information on the total weight of the grille and the required support.

### SUGGESTED CONDITIONS FOR TRACK MOUNTING

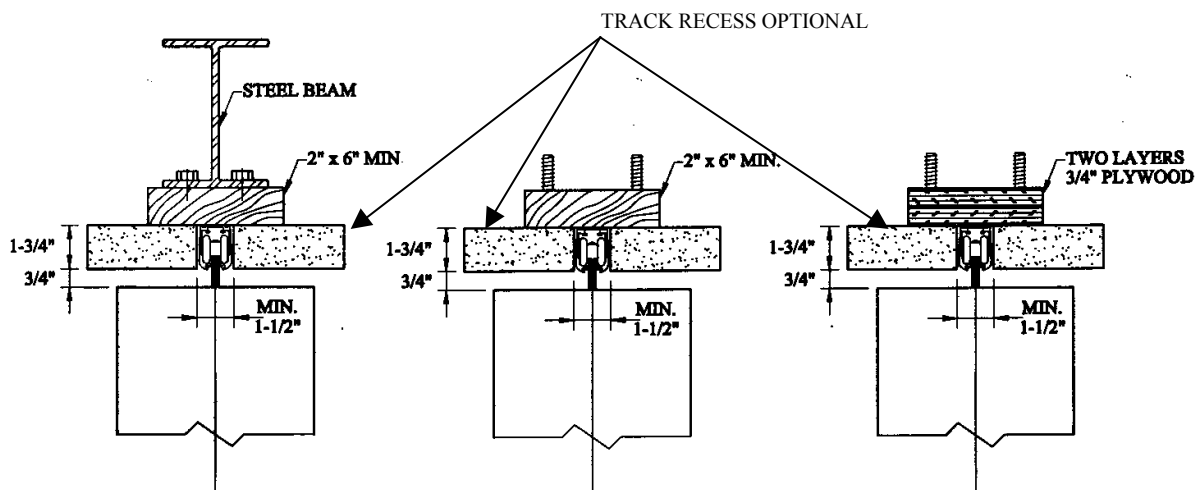

NOTE: FOR STRUCTURAL SUPPORT REQUIREMENTS CONSULT SHOP DRAWING FOR SPECIFIC GRILLE.

---

**Amstel**

111 CARLAUREN ROAD  
WOODBIDGE, ONTARIO, L4L 8A8  
TEL.(905) 850-7122 FAX.(905) 850-7336  
1-800-663-6206

## GENERAL STEPS FOR INSTALLATION:

### STAGE 1 – INSTALL OVERHEAD TRACK

Step 1

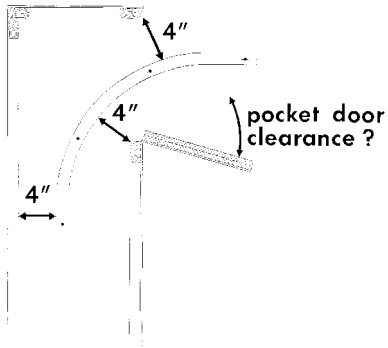

Step 2

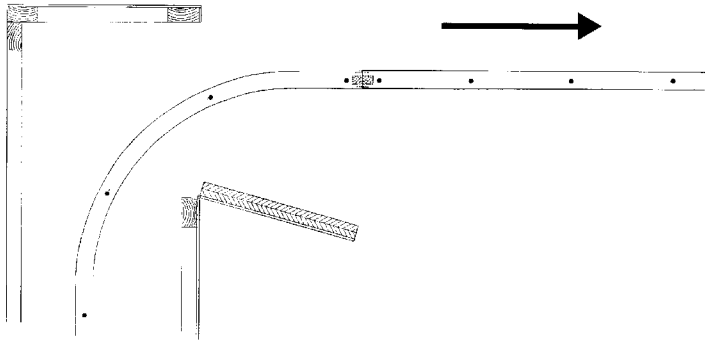

Step 3

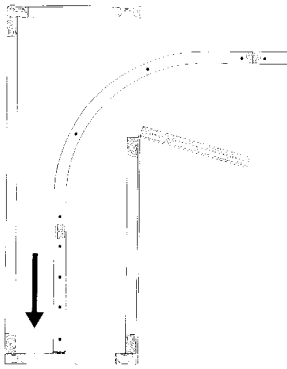

**Step 1.** Install track curves (if applicable) or straight track at storage pockets first. Maintain clearance for the folded grille by measuring at least 4" to the outside of the track. See illustration.

**Step 2.** Working outwards from the storage pocket begin installing subsequent portions of track. Chalk lines are useful for marking straight sections. See illustration.

**Step 3.** Install track into the storage pocket, maintaining clearance around studs, wiring, sprinkler heads, etc.. Use additional screws to carry the extra load of a stacked grille in this area.

### **Fastening Consecutive Pieces of Track:**

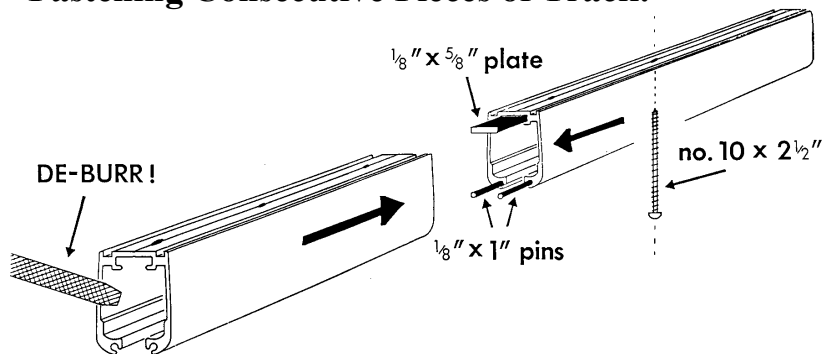

## STAGE 2 – HANGING THE GRILLE

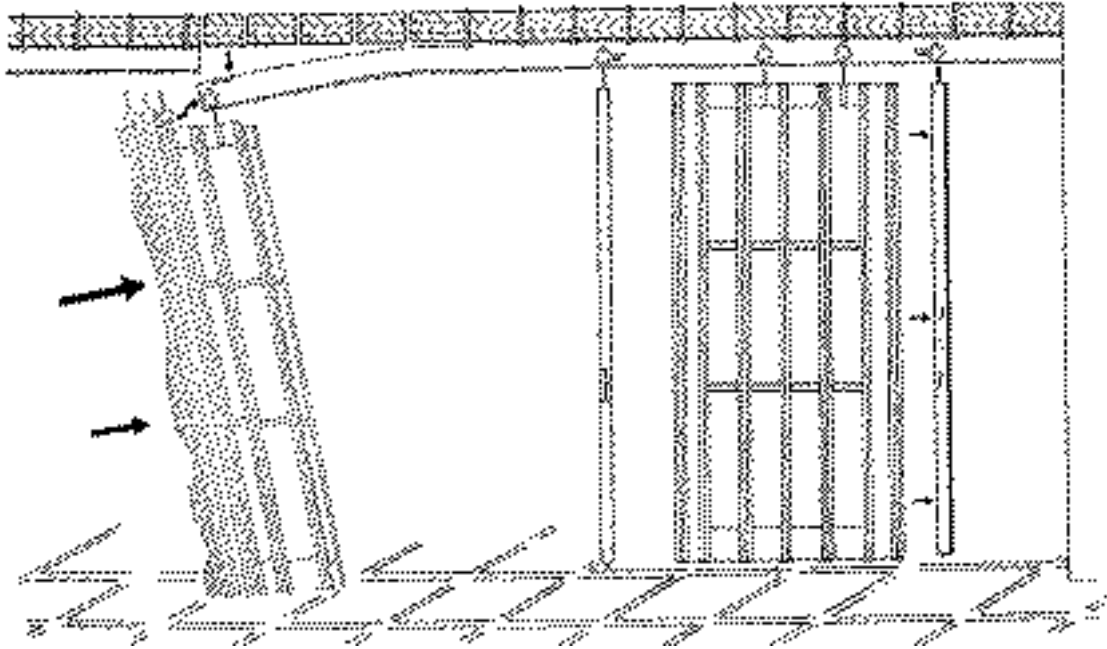

**Note:** You do not have to join lock posts to grille curtain until after they are all hanging from the track.

Refer to illustration: Feeding Grille and Posts onto Track.

**Step 1.** Open a track joint by sliding connecting plate and pins out of the splice. (See illustration Fastening Consecutive Pieces of Track as reference). Remove screws fastened into structural support for a distance of approximately four or five feet from the open track joint.

**Step 2.** While resting the bottom of the grille on the floor, feed the posts and curtain sections into the track according to the order on the layout drawing. Make note of post types, cylinder locations and orientation when doing so. Pre-drilled connecting holes are located on the inside of posts. Curtain section lengths are marked on the layout drawing. (Example: 14 P = 14 full width folding panels).

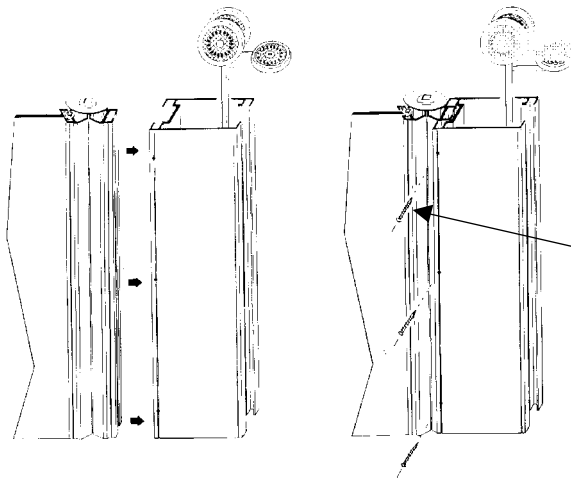

Drive 1/8" x 1" Tek point screws into pre-drilled holes, through grille curtain extrusion.

**Step 3.** Connect lock posts to the grille curtain sections after they are hanging from the track. (See illustration to left).

**#6 POST  
INSTALLATION  
DETAIL**

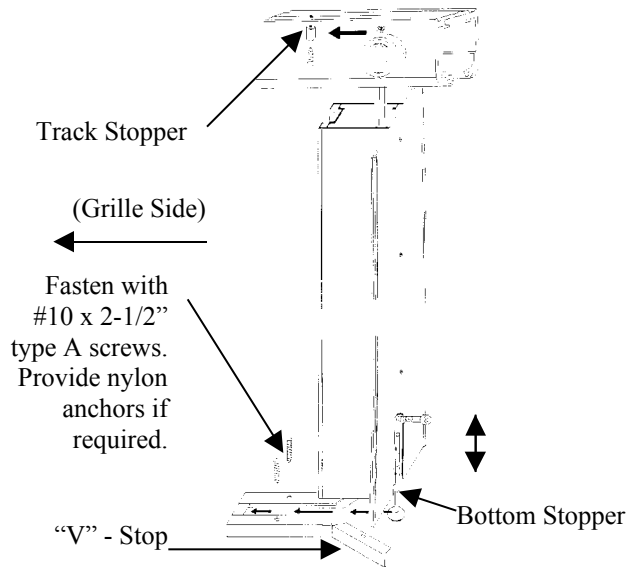

**SPECIFIC DETAILS FOR #6 POST  
INSTALLATION**

**Step 1.** Stretch the assembled grille across the opening, positioning the #6 post as deeply into the storage pocket as it will go (without tensioning the grille)

**Step 2.** Install the "V"-stop with the closed end directly under the bottom stopper. Bend wings out on "V"-stop as per detail. Adjust bottom stopper downward until it catches on "V"-stop but before it touches the floor.

**Step 3.** Push the grille into the storage pocket and screw the track stopper into the inside centreline of the track, directly above the closed end of the "V" stop. The #6 post should catch at the top and bottom, while still allowing the rest of the grille to pass.

**#7 POST  
INSTALLATION  
DETAIL**

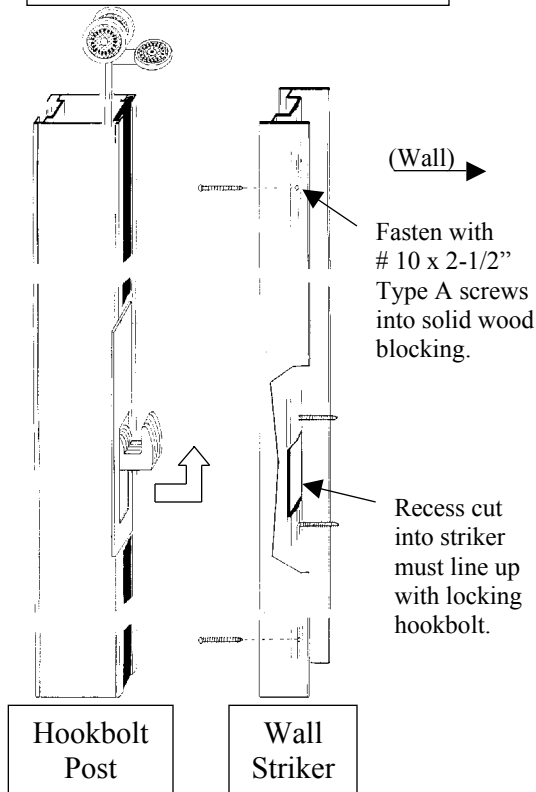

**#8 POST  
INSTALLATION  
DETAIL**

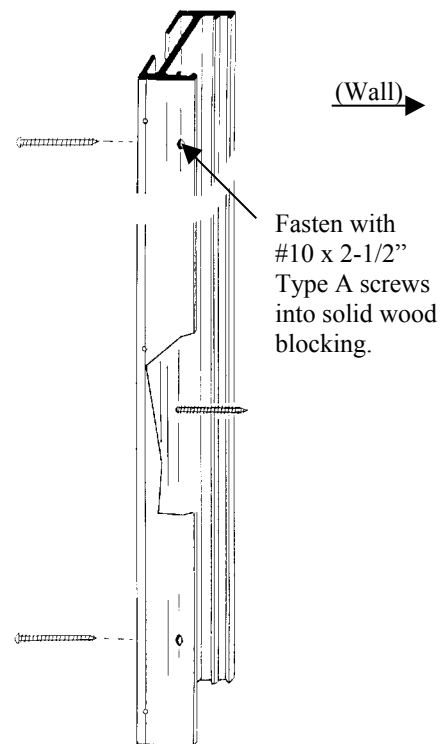

## SPECIFIC DETAILS FOR #2, #3, #4 AND #5 POST INSTALLATIONS

### **#2 POST INSTALLATION DETAILS** (Also applies to #3, #4, #5)

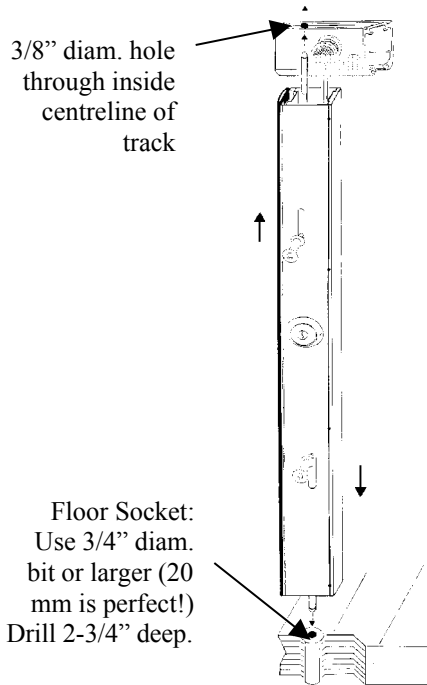

**Step 1.** If you are installing a #2 post, lightly snug the post up against the wall or pocket door. Using a spirit level, make sure that the post is plumb. Move the bottom lock knob down until the bottom rod touches the floor. Mark the spot, then drill straight down for about 2-3/4" with the appropriate drill bit for the floor or counter material.

**Step 2.** Applies to #2 post ONLY: Lock the bottom bolt into the floor socket. Leveling the post, firmly push the top bolt up until it hits the inside top of the track. Repeat this action several times until it leaves a clear mark. Drill STRAIGHT UPWARD at this mark through the top of the track and through the support. Carefully clean any aluminum or other debris from the track.

**Step 3.** Lock and unlock the post several times. If the bottom rod sticks, the floor socket may be installed too close to the wall. If the top rod sticks, the hole into the support may not be straight up and down. Be careful not to jam the bottom bolt all the way down into the floor socket.

## SPECIAL INSTRUCTIONS FOR DRILLING FLOORS AND COUNTERS

Install end posts and then middle posts so that the grille curtain is evenly distributed in the opening.

A masonry bit of 3/4" diam. or larger is necessary for drilling into concrete or tile. A good coring bit is highly recommended for drilling through marble, granite or delicate tile.

Tile glues and grout should harden for at least 24 hours prior to drilling the floor. Remember that if there are any voids under the tile, the tile will likely break. Avoid drilling through the edges or corners of tiles.

When drilling through carpet, cut a small cross through the fabric and fold it back out of the way. Drill into the bare floor underneath. Make sure that no carpet threads wind around the drill bit.

## MAINTENANCE INSTRUCTIONS FOR SLIDING GRILLES

1. Keep track clean and regularly inspect for damage.
2. Damaged sections should be replaced immediately. Damaged sections cause undue stress during the operation of the grille and can result in injury to the operator and others.
3. Inspect hinge screws to ensure that they remain tight. Damaged hinges should be replaced immediately.
4. Track joints should always be tight and secure.
5. Floor sockets should be kept free of dirt and debris.
6. Rollers should be checked for wear and replaced when needed.
7. Rollers and track curves should be lubricated with WD-40 or equivalent type oil every four months or as required.
8. Keep aluminum clean with a damp rag and a non-abrasive cleaner. If unsure of cleaner, test it on a small inconspicuous area first. Glass should be cleaned with glass cleaner. If cleaner is sprayed on to aluminum, wipe off with a damp rag.
9. If grille support appears to be moving or falling, this will eventually cause damage to the grille and can result in personal and property damage. Immediately report any bulkhead failures to the contractor responsible for it's construction.
10. Keep door pocket clean and free of debris.

If regular inspection and proper maintenance is followed you can help to ensure trouble free use of your Amstel Folding Grille. Please contact us for the availability of maintenance programs. If you have any questions regarding your Amstel Folding Grille please contact us.

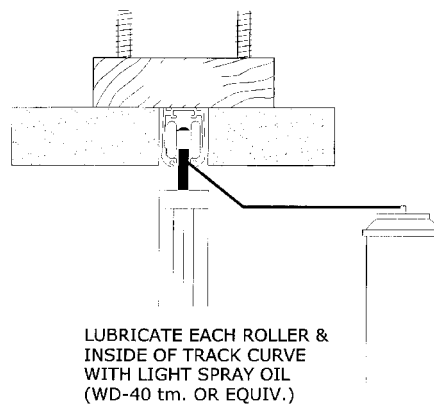

---

**Amstel**

111 CARLAUREN ROAD  
WOODBRIIDGE, ONTARIO, L4L 8A8  
TEL.(905) 850-7122 FAX.(905) 850-7336  
1-800-663-6206

## PANEL REMOVAL INSTRUCTIONS

Note: This procedure requires two workers. Remove the grille section from it's track, the lock posts from the grille curtain and lay the curtain section on the floor.

### Step 1

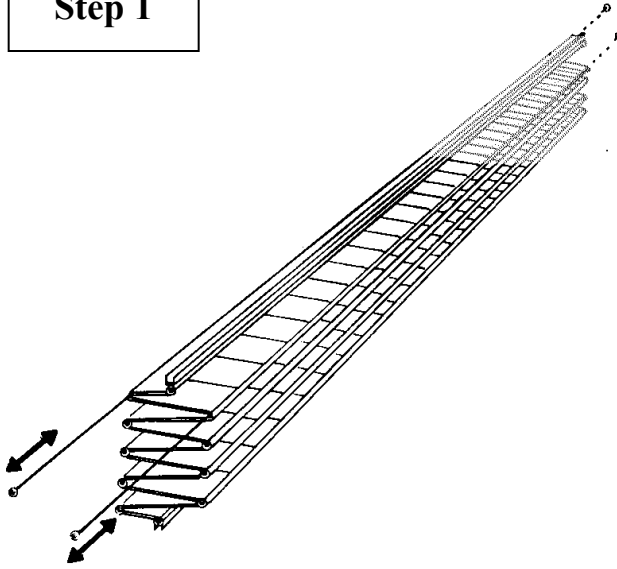

**Step 1.** Take a #2 square (Robertson type) screwdriver and clamp with vise-locking pliers to give the driver leverage. Use this driver to hold the screw at the end of a hinge rod while unthreading the other end. Remove the hinge rods on each side of the panels that you wish to remove.

### Step 2

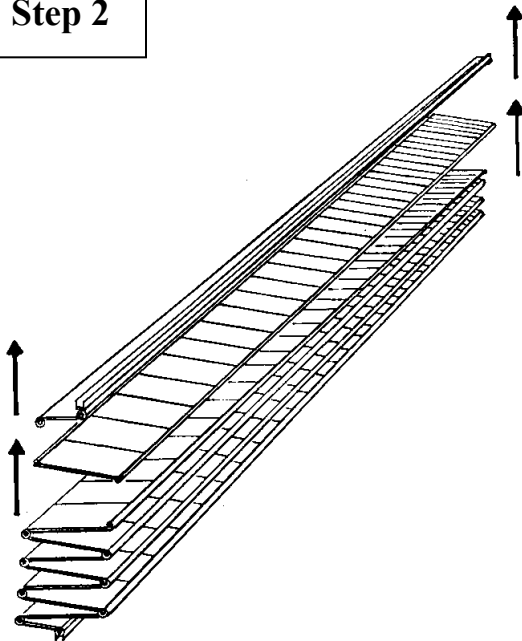

**Step 2.** Lift the top half of the panel and connecting hinges off of the top. Remove required panels.

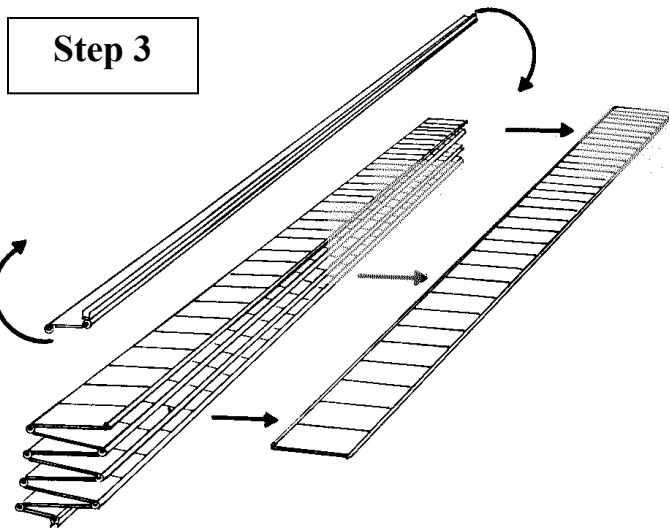

**Step 3.** If you have removed an even number of panels, then lower the half panel and connecting hinges straight down onto the remaining panels. If you have removed an odd number of panels, then you must rotate the half panel with it's connecting hinge end-for-end for 180 degrees and lower it onto the remaining panels.

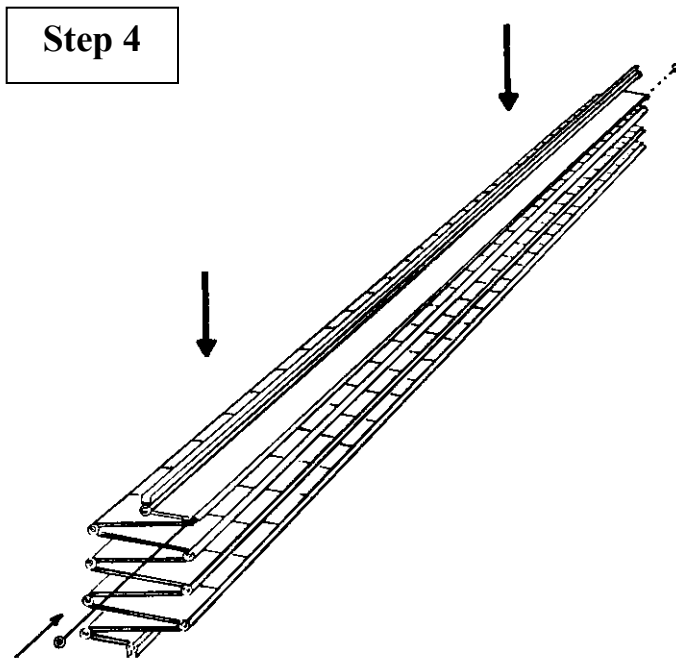

**Step 4.** Line up hinge components, replace the hinge washers and screws. Tighten by reversing Step 1.

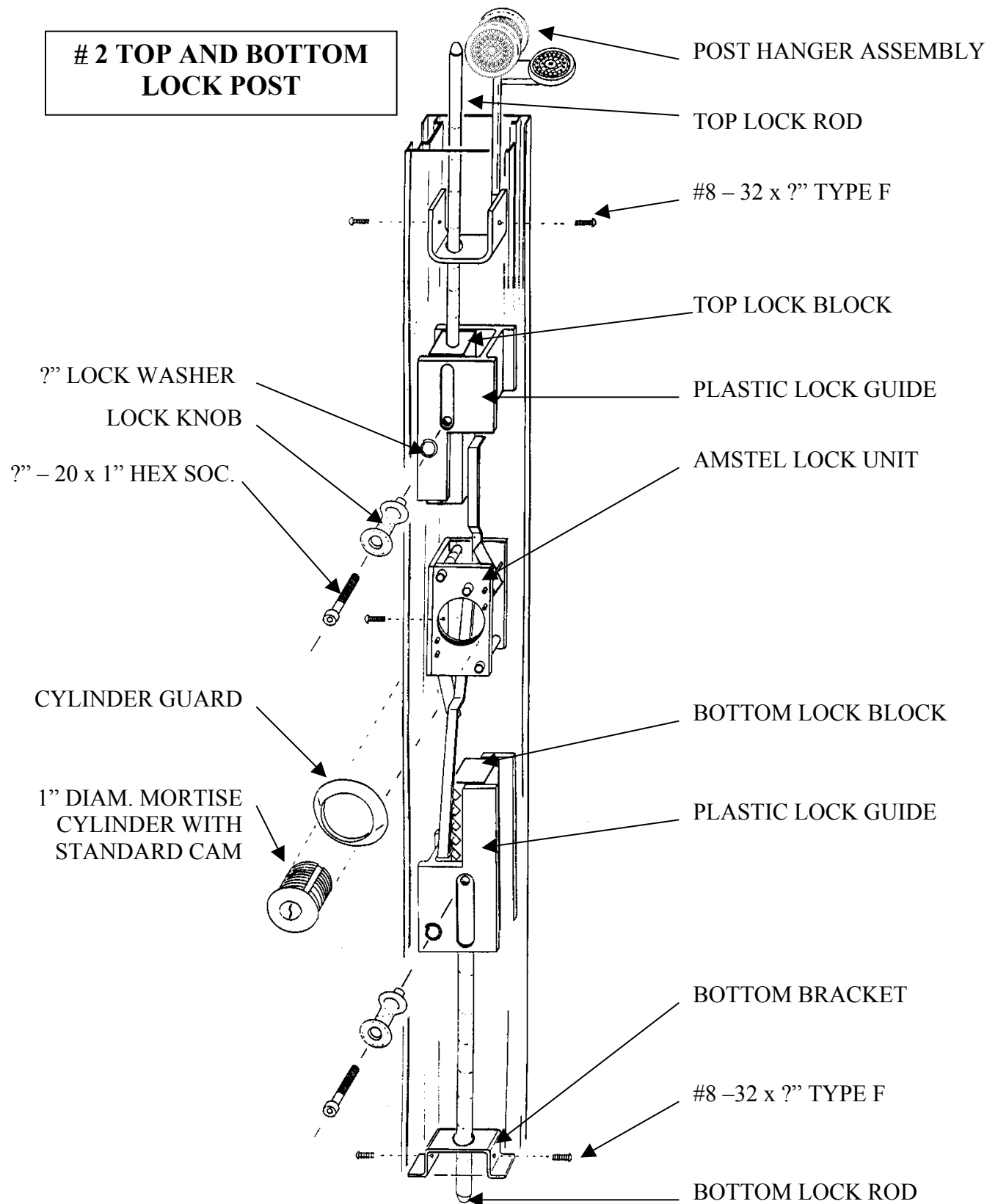

**Amstel**

111 CARLAUREN ROAD  
 WOODBRIDGE, ONTARIO, L4L 8A8  
 TEL.(905) 850-7122 FAX.(905) 850-7336  
 1-800-663-6206

**#3 CYLINDER  
INTERMEDIATE POST**

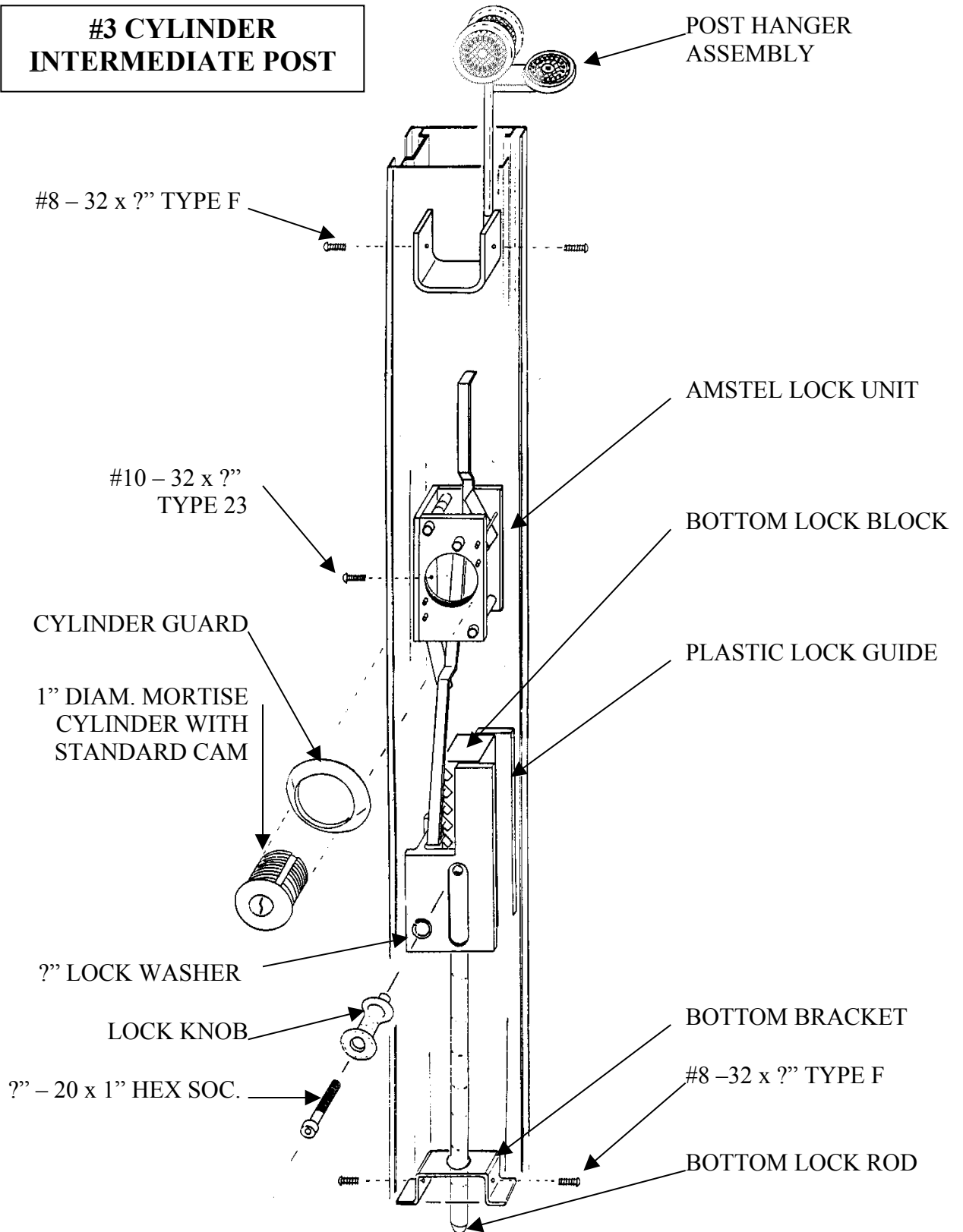

**Amstel**

111 CARLAUREN ROAD  
WOODBRIDGE, ONTARIO, L4L 8A8  
TEL.(905) 850-7122 FAX.(905) 850-7336  
1-800-663-6206

**#4 SPRING-KNOB  
INTERMEDIATE POST**

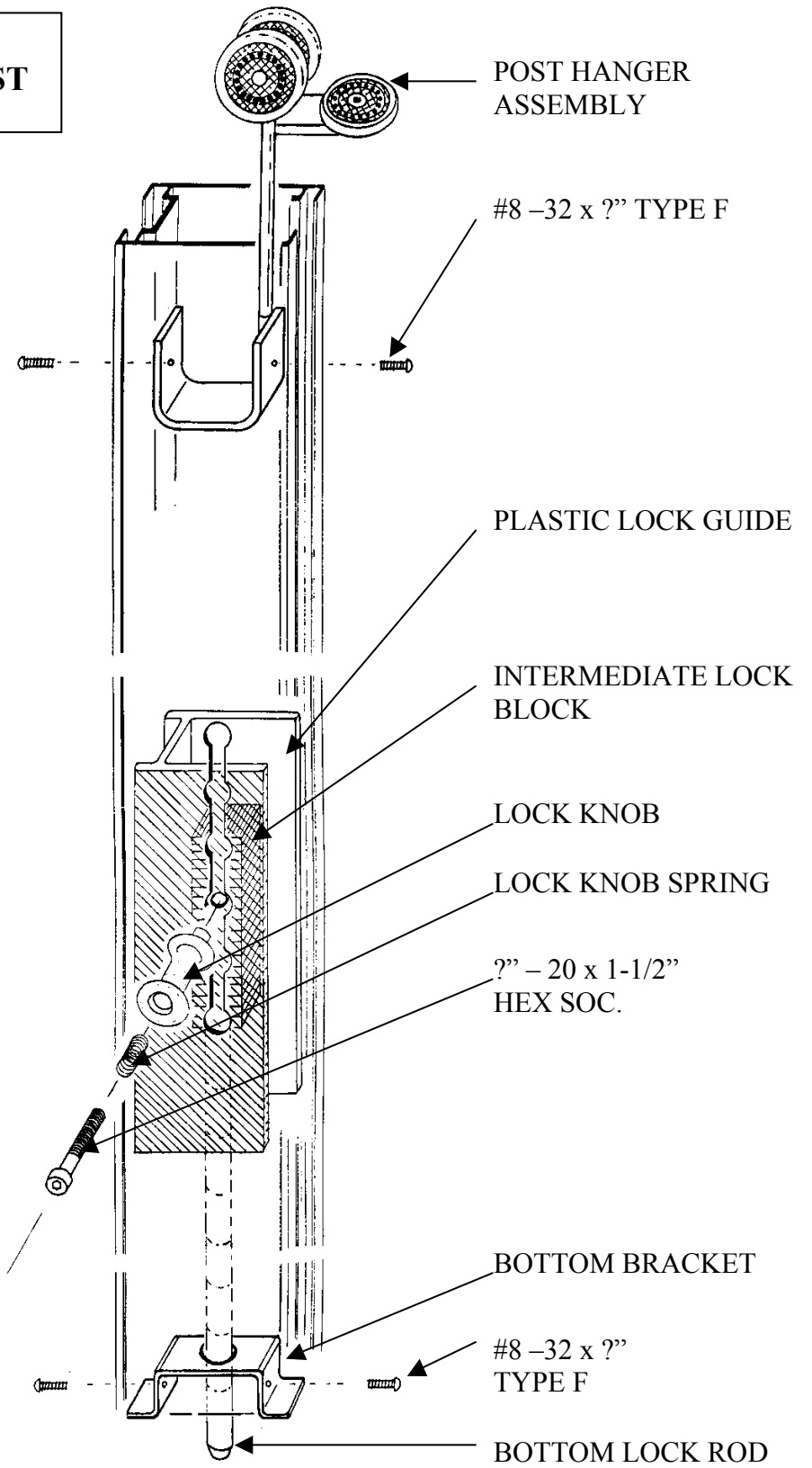

**#5 BIPARTING  
POSTS**

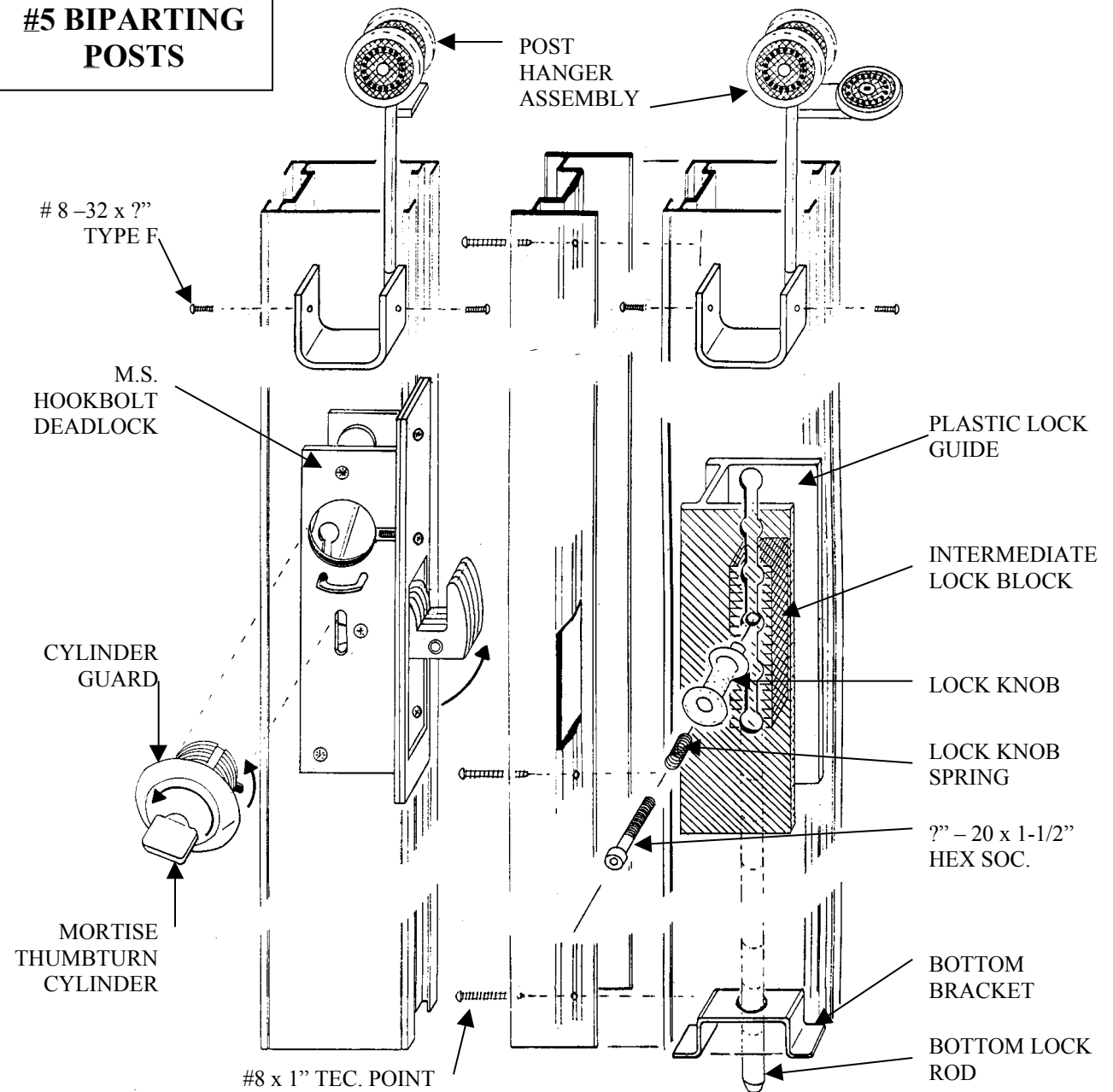

#6 SELF LOCKING POST

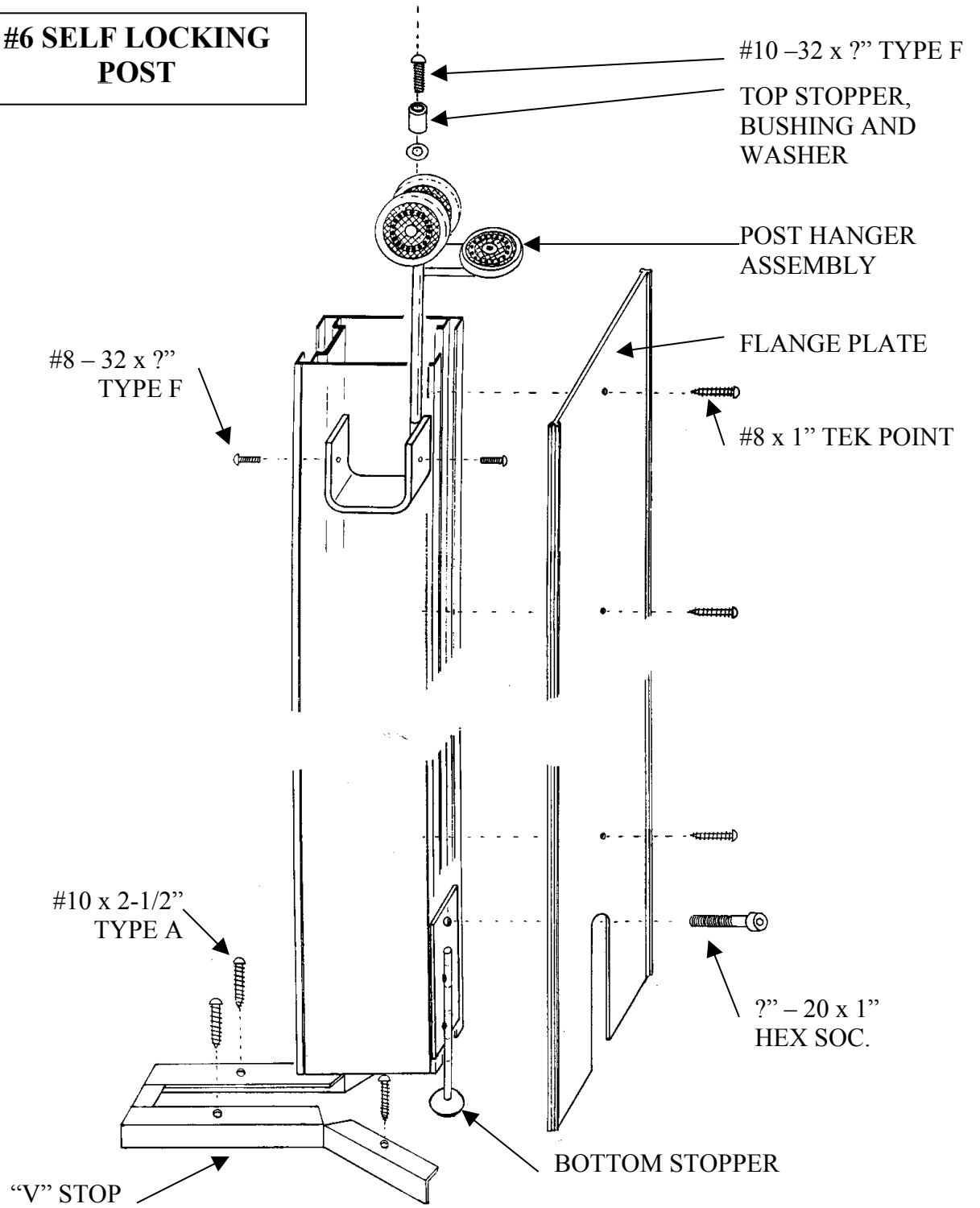

**#7 HOOKBOLT  
LOCK POST WITH  
WALL STRIKER**

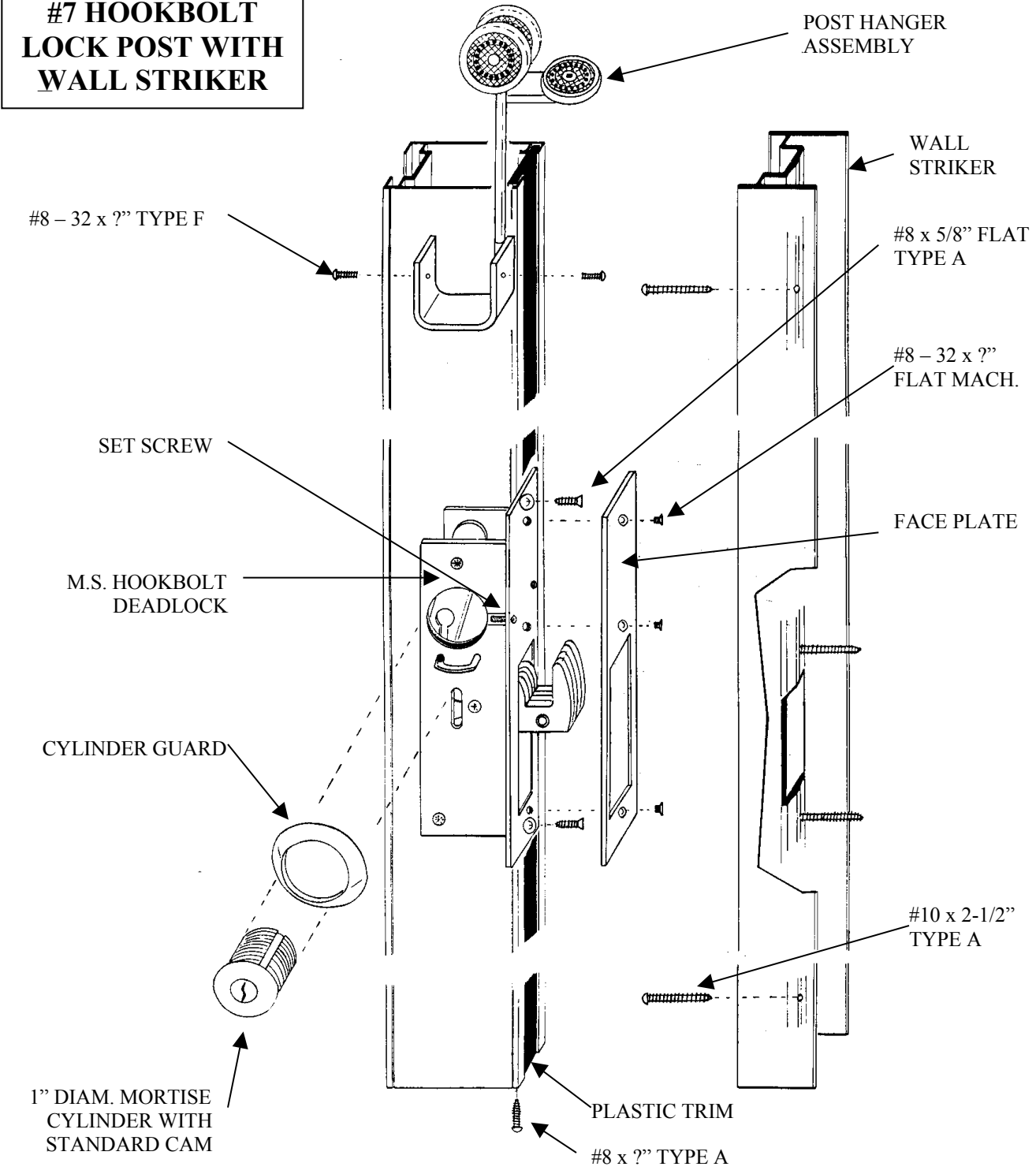

**#8 FIXED END POST**

#10 x 2-1/2" TYPE A

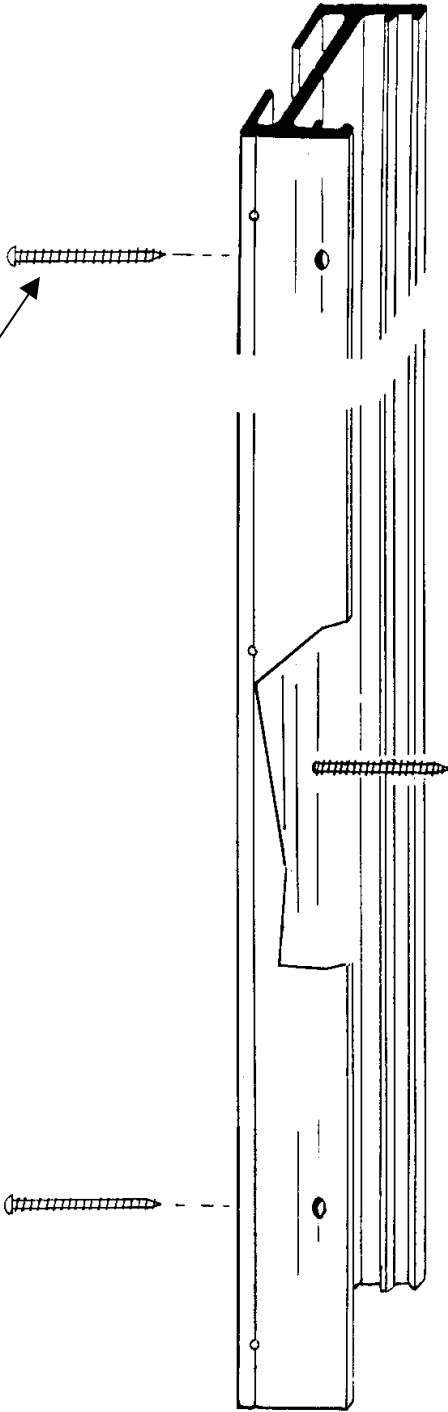

## BIPART EGRESS ASSEMBLY

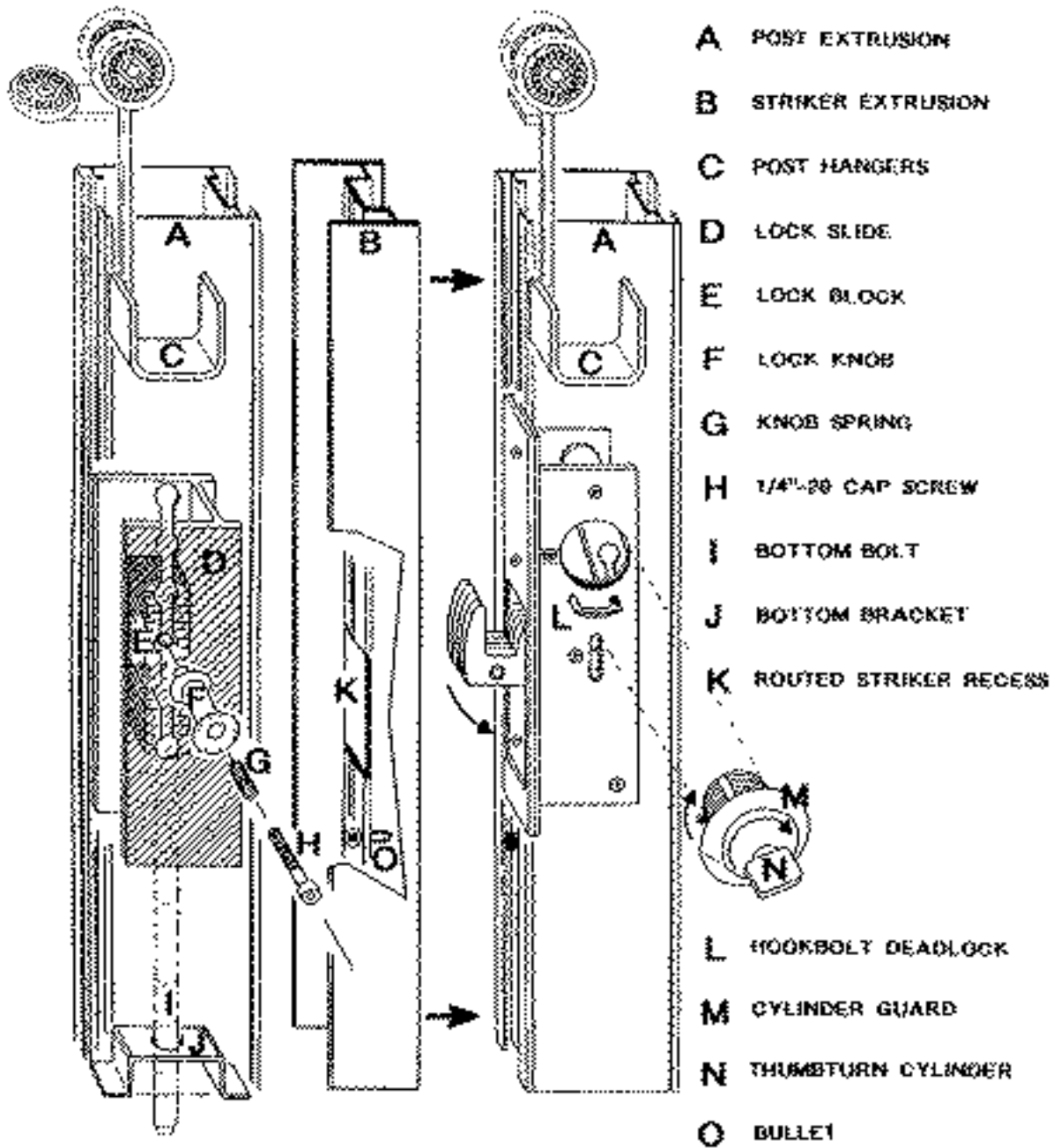

**Amstel**

111 CARLAUREN ROAD  
WOODBRIDGE, ONTARIO, L4L 8A8  
TEL.(905) 850-7122 FAX.(905) 850-7336  
1-800-663-6206

## BIPART EGRESS OPERATION

### TO LOCK

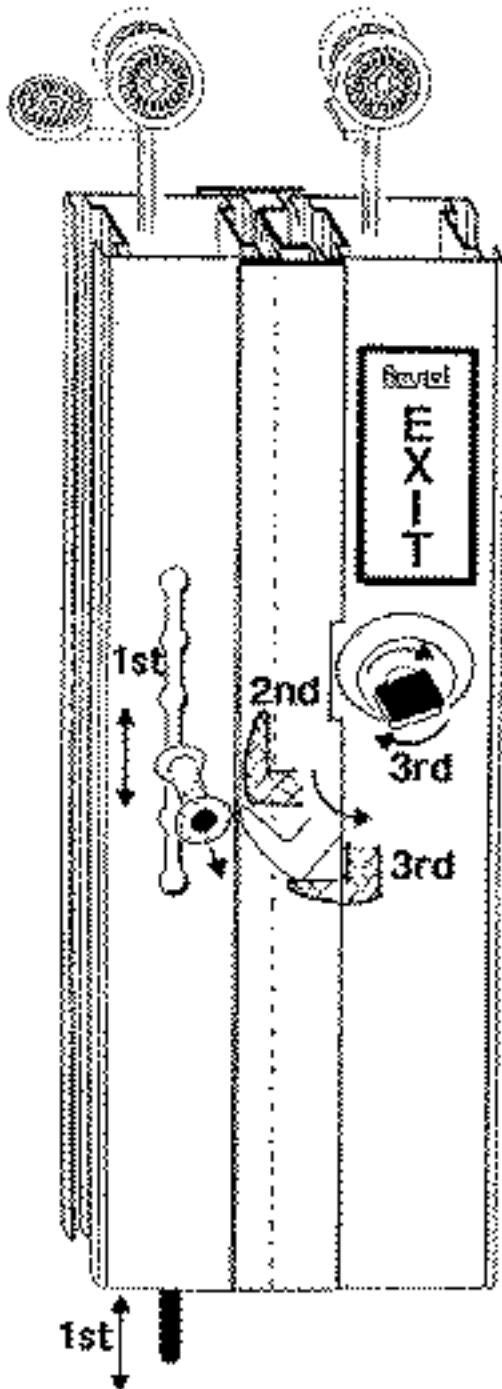

**1st** -PULL OUT LOCK KNOB

-PUSH BOTTOM BOLT DOWN  
INTO FLOOR

**2nd** -PUSH IN LOCK KNOB

-LOCK HOOKBOLT INTO STRIKER

(ROTATE THUMBTURN COUNTERCLOCKWISE)

### EMERGENCY UNLOCKING

**3rd** -ROTATE THUMBTURN CLOCKWISE  
TO UNLOCK HOOKBOLT

**4th** -PULL "EXIT" POST CLEAR  
OF STRIKER